

Drum-Type Diverter Valves VAR

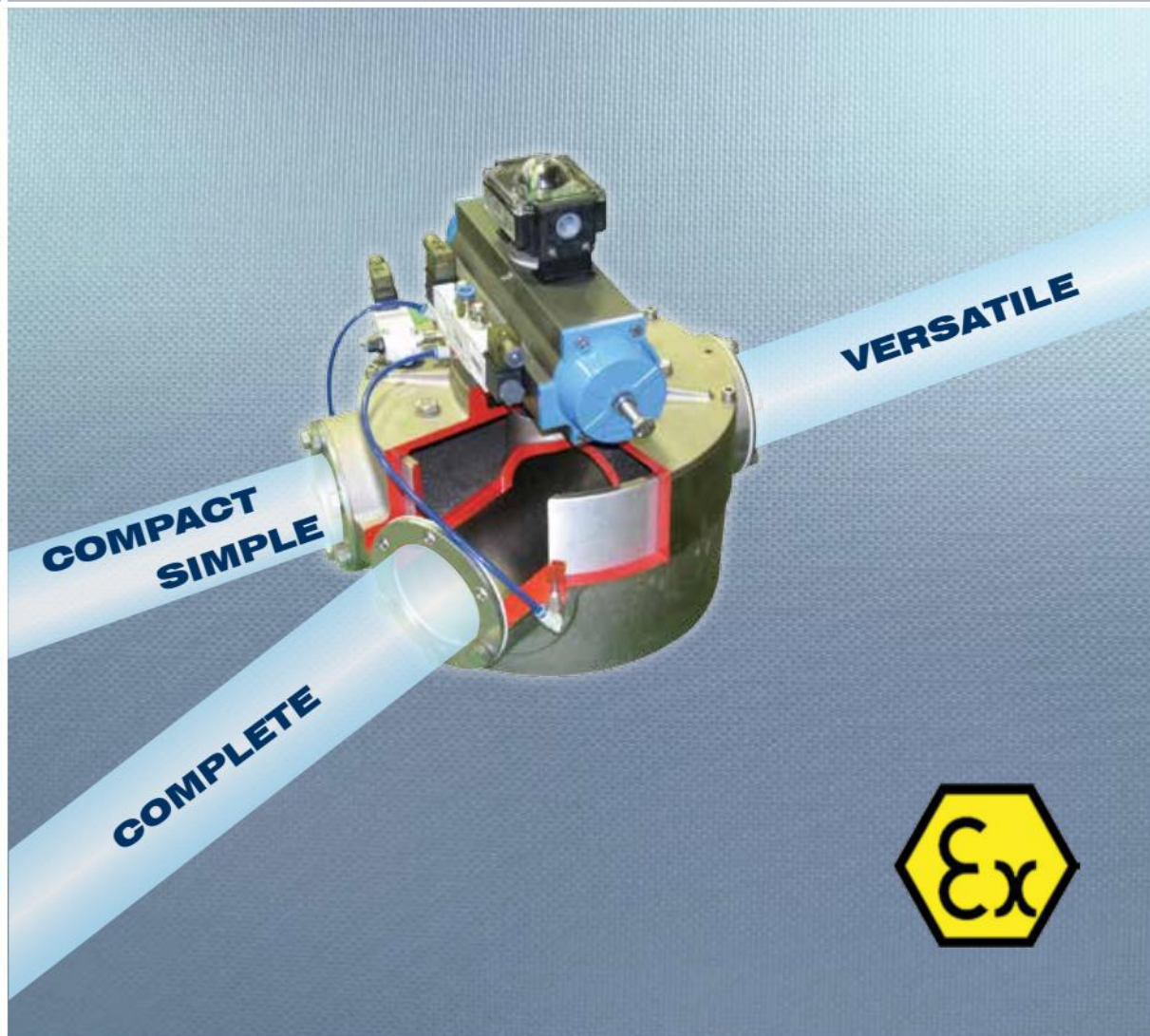

Drum-Type Diverter Valves VAR

THE MOST COMPACT, SIMPLE, COMPLETE AND VERSATILE DRUM DIVERTER VALVE ON THE MARKET

VAR Diverter Valves are suitable for handling any type of powdery or granular material in pneumatic conveying systems.

By means of the pneumatic actuator, which activates the rotating inner drum, the commutation of the tubular exit and, consequently, deviation of the material flow from one duct to another is obtained.

Features

VALVE

- Cast aluminium alloy casing;
- Pneumatic actuator in different voltages;
- Inflatable seals;
- Operating temperature: - 20°C to 80°C (-4°F to 176° F);
- Operating pressure: max. 3,5 bar (51 PSI);
- Stainless steel or nickel plated versions available (both with ATEX certification)

ACTUATOR

- Voltage supply: 24 V AC, 24 V DC, 110 V AC, 230 V AC;
- ATEX version available for Group II Cat. 1D/3D c T 135°C;

LINE DIVERSION CONTROL CARD

- Operating temperature: -20° C to 80° C (-4° F to 176° F).



Overall Dimensions

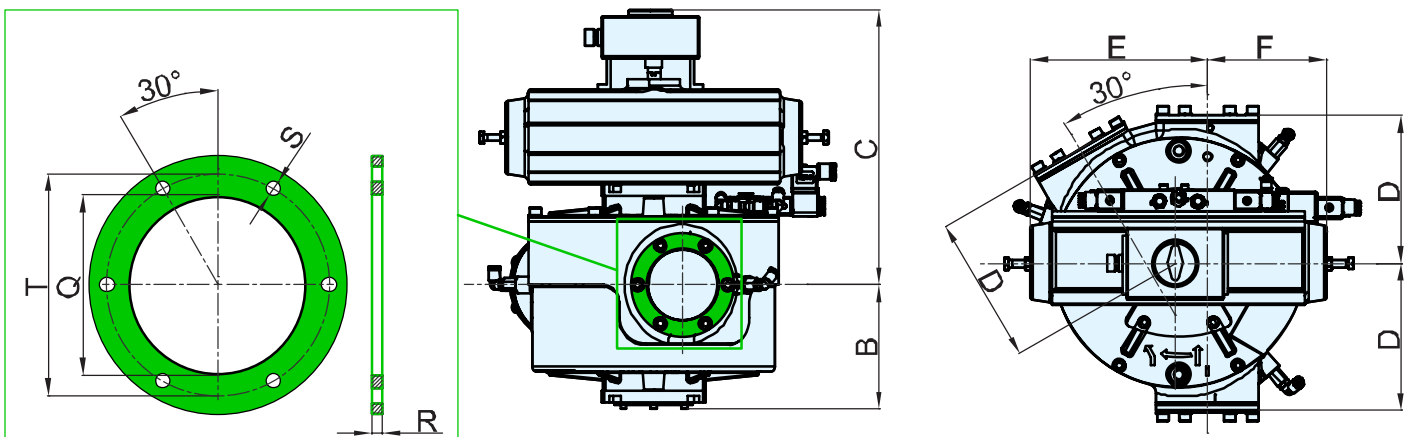

Type	B	C	D	E	F	T	Q	R	S
VAR 050	135	306	154	217	160	85	52	6	9
VAR 065							67		
VAR 080	142	326	169	260	174	103	82	10	11
VAR 100	148	332	209	266	160	127	102		
VAR 125	181	398	242	299	191	158	127		
VAR 150	197	414	273	305	184	185	158	10	11
VAR 175	216	469	313	432	197	217	177		
VAR 200	233	486	338	436	186	245	208		

Dimensions in mm

Benefits



Inflatable Seals = Standard

- Inflated while material is conveyed - perfect sealing;
- Deflated during rotation (i.e. material flow diversion), free drum movement and increased seal life;
- Minimum pressure drop inside conveying duct.

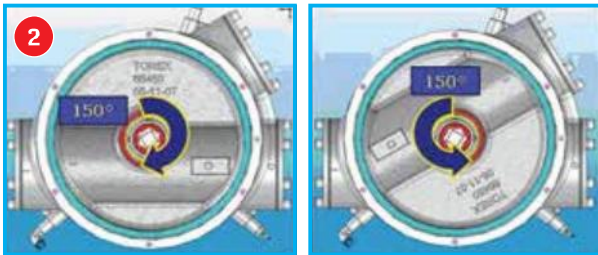

Adjustable and Easy to Use as Diverter or Converter

- Lightweight and compact overall dimensions;
- Easy to install;
- Maintenance-friendly;
- Actuator assembly on both sides of the casing.



Pneumatic Actuator with Material Flow Direction Indicator

- Visual arrow and mechanically through 2 limit switches.



Stainless Steel Version

- Prevent material contamination
- Suitable for use with mildly abrasive products.



Tungsten Carbide Anti-wear Treatment

- Used for erosive and abrasive wear applications.



Nickel Plated Version

- Increased resistance to corrosion
- Higher surface hardness.

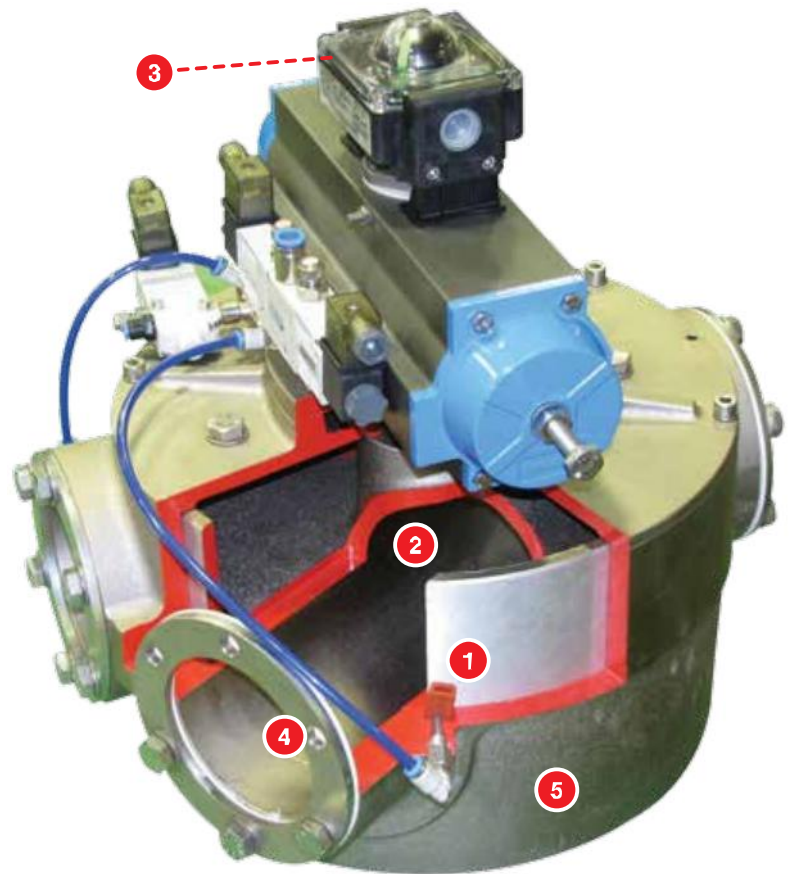

Accessories

Control Card for Duct Change



- Ensures smooth change sequence by coordinating pneumatic actuator operation and internal seals inflation.
- Detects the various stages of operation and provides, by means of a series of output signals, the condition of the valve warning of any malfunction.

Application



VAR Drum-Type Diverter Valves are essential components of all kinds of pneumatic conveying systems in those points where the material flow has to be diverted from one duct to another.



063001971 / May 2014 Rights reserved to modify technical specifications.



www.wamgroup.com